



COOLINGFAN

60 38
mm

Axial Fan 增压型风扇



常用规格 (General Specification:)

- ◆外框 (Frame) : PBT OF UL 94V-0
- ◆扇叶 (Impeller) : PBT OF UL 94V-0
- ◆轴承型号 (Bearing Type) : Sleeve Bearing & Ball Bearing
- ◆引线 (Lead Wires) : UL Type or Equivalent (+) : Red (-) : Black
- ◆马达保护 (Motor Protection) : Reverse Polarity Protected; Automatic Restart
- ◆工作温度和湿度 (Operating Temperature and Humidity) : -10°C~70°C, 5%~90%RH
- ◆储存温度和湿度 (Storage Temperature and Humidity) : -40°C~80°C, 5%~95%RH

风扇性能曲线 (Fan Performance Curve)

尺寸 (Dimensions) (Unit:mm)

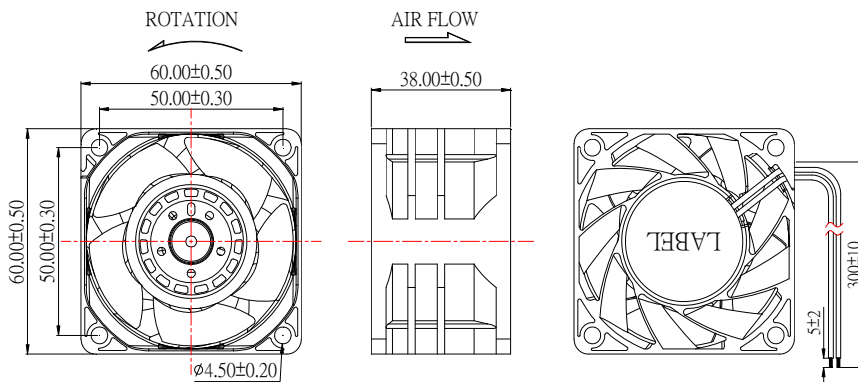
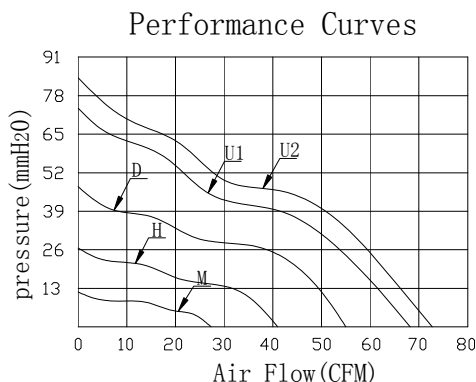

规格 (Specifications)

型号 Listed Model	额定电压 Rated Voltage	工作电压 Operating Voltage	额定电流 Rated Current	转速 Rated Speed	风量 Air Flow	风压 Static pressure	噪音 Noise Level	可选功能 Available Features (Optional)				重量 Weight
	(VDC)	(VDC)	(A)	(RPM)	(CFM)	(mmH2O)	(dBA)	转速侦测 Tachometer Output	锁机报警 Rotation Detector	温控 Thermal Control	脉冲调速 Pulse Width Modulation	g
DFX603812U	12	6.0~13.8	2.20	15,000	68.20	73.80	64.80	◆	◆	◆	◆	120
DFX603812D		6.0~13.8	1.20	12,000	54.50	47.30	59.00	◆	◆	◆	◆	
DFX603812H		6.0~13.8	0.60	9,000	40.90	26.60	51.50	◆	◆	◆	◆	
DFX603812M		6.0~13.8	0.40	6,000	27.30	11.80	40.90	◆	◆	◆	◆	
DFX603824U	24	12.0~27.6	1.20	16,000	72.70	84.00	66.50	◆	◆	◆	◆	
DFX603824D		12.0~27.6	0.60	12,000	54.50	47.30	59.00	◆	◆	◆	◆	
DFX603824H		12.0~27.6	0.30	9,000	40.90	26.60	51.50	◆	◆	◆	◆	
DFX603824M		12.0~27.6	0.15	6,000	27.30	11.80	40.90	◆	◆	◆	◆	
DFX603848U	48	28.0~56.0	0.60	16,000	72.70	84.00	66.50	◆	◆	◆	◆	
DFX603848D		28.0~56.0	0.30	12,000	54.50	47.30	59.00	◆	◆	◆	◆	
DFX603848H		28.0~56.0	0.20	9,000	40.90	26.60	51.50	◆	◆	◆	◆	
DFX603848M		28.0~56.0	0.10	6,000	27.30	11.80	40.90	◆	◆	◆	◆	

X:S:Sleeve Bearing or B: Ball Bearing or H:Hydro Bearing ; Specifications are subject to change without notice

